

**Taper bushes**

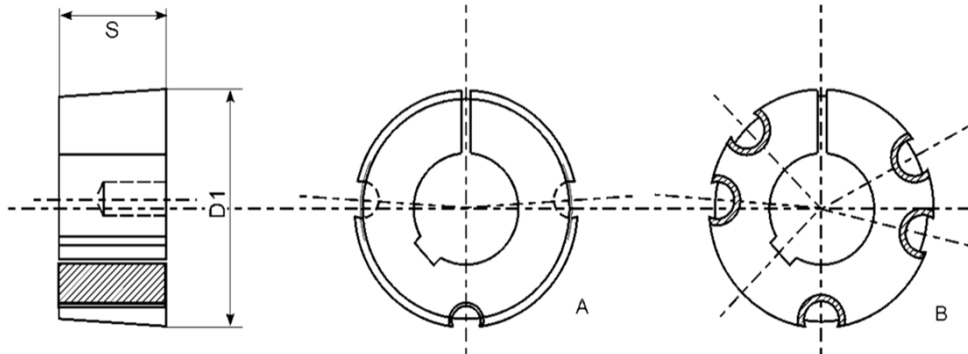

**Standard metric bore**

SIZE	Standard metric bore	Transmissible Torque	SCREWS B.S.W.	D1 (mm)	S (mm)	Type
1008	9 10 11 12 14 16 18 19 20 22 24 25	5.6	1/4" x 1/2"	35,0	22,3	A
1108	9 10 11 12 14 16 18 19 20 22 24 25 28*	5.6	1/4" x 1/2"	38,0	22,3	A
1210	11 12 14 16 18 19 20 22 24 25 28 30 32	19.6	3/8" x 5/8"	47,5	25,4	A
1215	14 19 20 24 25 28	19.6	3/8" x 5/8"	47,5	38,1	A
1610	14 16 18 19 20 22 24 25 28 30 32 35 38 40* 42*	19.6	3/8" x 5/8"	57,0	25,4	A
1615	14 16 18 19 20 22 24 25 28 30 32 35 38 40* 42*	19.6	3/8" x 5/8"	57,0	38,1	A
2012	14 16 18 19 20 22 24 25 28 30 32 35 38 40 42 45 48 50*	30.4	7/16" x 7/8"	70,0	31,8	A
2517	16 18 19 20 22 24 25 28 30 32 35 38 40 42 45 48 50 55 60	48	1/2" x 1"	85,5	44,5	A
3020	25 28 30 32 35 38 40 42 45 48 50 55 60 65 70 75	90	5/8" x 1" 1/4	108,0	50,8	A
3030	35 38 40 42 45 48 50 55 60 65 70 75	90	5/8" x 1" 1/2	108,0	76,2	A
3525	35 38 40 42 45 48 50 55 60 65 70 75 80	113	1/2" x 1" 1/2	127,0	64,9	B
3535	35 38 40 42 45 48 50 55 60 65 70 75 80 85 90*	113	1/2" x 1" 1/2	127,0	88,9	B
4030	40 42 45 48 50 55 60 65 70 75 80 85 90 100	169	5/8" x 1" 1/2	146,0	76,2	B
4040	40 42 45 48 50 55 60 65 70 75 80 85 90 100	169	5/8" x 1" 3/4	146,0	101,6	B
4535	55 60 65 70 75 80 85 90 100 105 110	192	3/4" x 2"	162,0	89,0	B
4545	55 60 65 70 75 80 85 90 100 105 110	192	3/4" x 2"	162,0	115,0	B
5040	70 75 80 85 90 100 105 110 115 120 125	272	7/8" x 2" 1/4	177,6	101,6	B
5050	70 75 80 85 90 100 105 110 115 120 125	272	7/8" x 2" 1/4	177,6	127,0	B

**Standard inch bore**

SIZE	Standard inch bore	Transmissible Torque	SCREWS B.S.W.	D1 (mm)	S (mm)	Type
1008	3/8 - 7/16 - 1/2 - 9/16 - 5/8 - 11/16 - 3/4 - 13/16 - 7/8 - 15/16 - 1" - 1 1/16" - 1 1/8"	5.6	1/4" x 1/2"	35,0	22,3	A
1108	3/8 - 7/16 - 1/2 - 9/16 - 5/8 - 11/16 - 3/4 - 13/16 - 7/8 - 15/16 - 1" - 1 1/16" - 1 1/8"	5.6	1/4" x 1/2"	38,0	22,3	A
1210	1/2 - 9/16 - 5/8 - 11/16 - 3/4 - 13/16 - 7/8 - 15/16 - 1" - 1 1/16" - 1 1/8" - 1 3/16" - 1 1/4" - 1 5/16" - 1 3/8"	19.6	3/8" x 5/8"	47,5	25,4	A
1215	1/2 - 9/16 - 5/8 - 11/16 - 3/4 - 13/16 - 7/8 - 15/16 - 1" - 1 1/16" - 1 1/8" - 1 3/16" - 1 1/4" - 1 5/16" - 1 3/8"	19.6	3/8" x 5/8"	47,5	38,1	A
1610	1/2 - 9/16 - 5/8 - 11/16 - 3/4 - 13/16 - 7/8 - 15/16 - 1" - 1 1/16" - 1 1/8" - 1 3/16" - 1 1/4" - 1 5/16" - 1 3/8" - 1 7/16" - 1 1/2" - 1 5/8"	19.6	3/8" x 5/8"	57,0	25,4	A
1615	1/2 - 9/16 - 5/8 - 11/16 - 3/4 - 13/16 - 7/8 - 15/16 - 1" - 1 1/16" - 1 1/8" - 1 3/16" - 1 1/4" - 1 5/16" - 1 3/8" - 1 7/16" - 1 1/2" - 1 5/8"	19.6	3/8" x 5/8"	57,0	38,1	A
2012	3/4 - 13/16 - 7/8 - 15/16 - 1" - 1 1/16" - 1 1/8" - 1 3/16" - 1 1/4" - 1 5/16" - 1 3/8" - 1 7/16" - 1 1/2" - 1 5/8" - 1 3/4" - 1 7/8" - 2"	30.4	7/16" x 7/8"	70,0	31,8	A
2517	3/4 - 7/8 - 15/16 - 1" - 1 1/16" - 1 1/8" - 1 3/16" - 1 1/4" - 1 5/16" - 1 3/8" - 1 7/16" - 1 1/2" - 1 5/8" - 1 3/4" - 1 7/8" - 2" - 2 1/8" - 2 1/4" - 2 3/8" - 2 1/2"	48	1/2" x 1"	85,5	44,5	A
3020	1 1/4" - 1 5/16" - 1 3/8" - 1 7/16" - 1 1/2" - 1 5/8" - 1 3/4" - 1 7/8" - 2" - 2 1/8" - 2 1/4" - 2 3/8" - 2 1/2" - 2 5/8" - 2 3/4" - 2 7/8" - 3"	90	5/8" x 1" 1/4	108,0	50,8	A
3030	1 1/4" - 1 5/16" - 1 3/8" - 1 7/16" - 1 1/2" - 1 5/8" - 1 3/4" - 1 7/8" - 2" - 2 1/8" - 2 1/4" - 2 3/8" - 2 1/2" - 2 5/8" - 2 3/4" - 2 7/8" - 3"	90	5/8" x 1" 1/2	108,0	76,2	A
3525	1 1/2" - 1 5/8" - 1 3/4" - 1 7/8" - 2" - 2 1/8" - 2 1/4" - 2 3/8" - 2 1/2" - 2 5/8" - 2 3/4" - 2 7/8" - 3" - 3 1/8" - 3 1/4" - 3 3/8" - 3 1/2"	113	1/2" x 1" 1/2	127,0	64,9	B
3535	1 1/2" - 1 5/8" - 1 3/4" - 1 7/8" - 2" - 2 1/8" - 2 1/4" - 2 3/8" - 2 1/2" - 2 5/8" - 2 3/4" - 2 7/8" - 3" - 3 1/8" - 3 1/4" - 3 3/8" - 3 1/2"	113	1/2" x 1" 1/2	127,0	88,9	B
4030	1 3/4" - 1 7/8" - 2" - 2 1/8" - 2 1/4" - 2 3/8" - 2 1/2" - 2 5/8" - 2 3/4" - 2 7/8" - 3" - 3 1/8" - 3 1/4" - 3 3/8" - 3 1/2" - 3 3/4" - 4"	169	5/8" x 1" 1/2	146,0	76,2	B
4040	1 3/4" - 1 7/8" - 2" - 2 1/8" - 2 1/4" - 2 3/8" - 2 1/2" - 2 5/8" - 2 3/4" - 2 7/8" - 3" - 3 1/8" - 3 1/4" - 3 3/8" - 3 1/2" - 3 3/4" - 4"	169	5/8" x 1" 3/4	146,0	101,6	B
4535	2" - 2 1/8" - 2 1/4" - 2 3/8" - 2 1/2" - 2 5/8" - 2 3/4" - 2 7/8" - 3" - 3 1/8" - 3 1/4" - 3 3/8" - 3 1/2" - 3 3/4" - 4"	192	3/4" x 2"	162,0	89,0	B
4545	2" - 2 1/8" - 2 1/4" - 2 3/8" - 2 1/2" - 2 5/8" - 2 3/4" - 2 7/8" - 3" - 3 1/8" - 3 1/4" - 3 3/8" - 3 1/2" - 3 3/4" - 4"	192	3/4" x 2"	162,0	115,0	B
5040	2 3/4" - 2 7/8" - 3" - 3 1/8" - 3 1/4" - 3 3/8" - 3 1/2" - 3 3/4" - 4" - 4 1/4" - 4 1/2" - 4 3/4" - 5"	272	7/8" x 2" 1/4	177,6	101,6	B
5050	2 3/4" - 2 7/8" - 3" - 3 1/8" - 3 1/4" - 3 3/8" - 3 1/2" - 3 3/4" - 4" - 4 1/4" - 4 1/2" - 4 3/4" - 5"	272	7/8" x 2" 1/4	177,6	127,0	B

**Taper bushings (Bore & keyway information)**

1008 bushings	Standard bore	Keyway (WxD)
1008	9	3x1.40
	10	3x1.40
	11	4x1.80
	12	4x1.80
	14	5x2.30
	15	5x2.30
	16	5x2.30
	18	6x2.80
	19	6x2.80
	20	6x2.80
	22	6x2.80
	24*	8x2.00
	25*	8x1.30

1108 bushings	Standard bore	Keyway (WxD)
1108	9	3x1.40
	10	3x1.40
	11	4x1.80
	12	4x1.80
	14	5x2.30
	15	5x2.30
	16	5x2.30
	18	6x2.80
	19	6x2.80
	20	6x2.80
	22	6x2.80
	24	8x3.30
	25	8x3.30
28*	8x2.00	

1210 bushings	Standard bore	Keyway (WxD)
1210	11	4x1.80
	12	4x1.80
	14	5x2.30
	15	5x2.30
	16	5x2.30
	18	6x2.80
	19	6x2.80
	20	6x2.80
	22	6x2.80
	24	8x3.30
	25	8x3.30
	28	8x3.30
	30	8x3.30
32	10x3.30	

1215 bushings	Standard bore	Keyway (WxD)
1215	11	4x1.80
	12	4x1.80
	14	5x2.30
	16	5x2.30
	18	6x2.80
	19	6x2.80
	20	6x2.80
	22	6x2.80
	24	8x3.30
	25	8x3.30
	28	8x3.30
	30	8x3.30
	32	10x3.30

1310 bushings	Standard bore	Keyway (WxD)
1310	14	5x2.30
	16	5x2.30
	18	6x2.80
	19	6x2.80
	20	6x2.80
	22	6x2.80
	24	8x3.30
	25	8x3.30
	28	8x3.30
	30	8x3.30
	32	10x3.30
	35	10x3.30

1610	Standard	Keyway
1610	14	5x2.30
	15	5x2.30
	16	5x2.30
	18	6x2.80
	19	6x2.80
	20	6x2.80
	22	6x2.80
	24	8x3.30
	25	8x3.30
	28	8x3.30
	30	8x3.30
	32	10x3.30
	35	10x3.30
38	10x3.30	
40	12x3.30	
42*	12x2.20	

1615	Standard	Keyway
1615	14	5x2.30
	16	5x2.30
	18	6x2.80
	19	6x2.80
	20	6x2.80
	22	6x2.80
	24	8x3.30
	25	8x3.30
	28	8x3.30
	30	8x3.30
	32	10x3.30
	35	10x3.30
	38	10x3.30
40	12x3.30	
42*	12x2.20	

2012	Standard	Keyway
2012	14	5x2.30
	16	5x2.30
	18	6x2.80
	19	6x2.80
	20	6x2.80
	22	6x2.80
	24	8x3.30
	25	8x3.30
	28	8x3.30
	30	8x3.30
	32	10x3.30
	35	10x3.30
	38	10x3.30
40	12x3.30	
42	12x3.30	
45	14x3.80	
48	14x3.80	
50	14x3.80	

2517 bushings	Standard bore	Keyway (WxD)
2517	16	5x2.30
	18	6x2.80
	19	6x2.80
	20	6x2.80
	22	6x2.80
	24	8x3.30
	25	8x3.30
	28	8x3.30
	30	8x3.30
	32	10x3.30
	35	10x3.30
	38	10x3.30
	40	12x3.30
	42	12x3.30
	45	14x3.80
	48	14x3.80
	50	14x3.80
	55	16x4.30
	60	18x4.40

3020 bushings	Standard bore	Keyway (WxD)
3020	25	8x3.30
	28	8x3.30
	30	8x3.30
	32	10x3.30
	35	10x3.30
	38	10x3.30
	40	12x3.30
	42	12x3.30
	45	14x3.80
	48	14x3.80
	50	14x3.80
	55	16x4.30
	60	18x4.40
65	18x4.40	
70	20x4.90	
75	20x4.90	

3030 bushings	Standard bore	Keyway (WxD)
3030	35	10x3.30
	38	10x3.30
	40	12x3.30
	42	12x3.30
	45	14x3.80
	48	14x3.80
	50	14x3.80
	55	16x4.30
	60	18x4.40
	65	18x4.40
	70	20x4.90
	75	20x4.90

\* = Shallow key

**Taper bushings (Metric bore & keyway information)**

3525 bushings	Standard bore	Keyway (WxD)
3525	35	10x3.30
	38	10x3.30
	40	12x3.30
	42	12x3.30
	45	14x3.80
	48	14x3.80
	50	14x3.80
	55	16x4.30
	60	18x4.40
	65	18x4.40
	70	20x4.90
	75	20x4.90
	80	22x5.40
	85	22x5.40
	90	25x5.40

4030 bushings	Standard bore	Keyway (WxD)
4030	40	12x3.30
	42	12x3.30
	45	14x3.80
	48	14x3.80
	50	14x3.80
	55	16x4.30
	60	18x4.40
	65	18x4.40
	70	20x4.90
	75	20x4.90
	80	22x5.40
	85	22x5.40
	90	25x5.40
	100	28x6.40

4545 bushings	Standard bore	Keyway (WxD)
4545	55	16x4.30
	60	18x4.40
	65	18x4.40
	70	20x4.90
	75	20x4.90
	80	22x5.40
	85	22x5.40
	90	25x5.40
	95	25x5.40
	100	28x6.40
	105	28x6.40
	110	28x6.40

3535 bushings	Standard bore	Keyway (WxD)
3535	35	10x3.30
	38	10x3.30
	40	12x3.30
	42	12x3.30
	45	14x3.80
	48	14x3.80
	50	14x3.80
	55	16x4.30
	60	18x4.40
	65	18x4.40
	70	20x4.90
	75	20x4.90
	80	22x5.40
	85	22x5.40
	90	25x5.40

4040 bushings	Standard bore	Keyway (WxD)
4040	40	12x3.30
	42	12x3.30
	45	14x3.80
	48	14x3.80
	50	14x3.80
	55	16x4.30
	60	18x4.40
	65	18x4.40
	70	20x4.90
	75	20x4.90
	80	22x5.40
	85	22x5.40
	90	25x5.40
	95	25x5.40
	100	28x6.40

5040 bushings	Standard bore	Keyway (WxD)
5040	70	20x4.90
	75	20x4.90
	80	22x5.40
	85	22x5.40
	90	25x5.40
	95	25x5.40
	100	28x6.40
	105	28x6.40
	110	28x6.40
	115	32x7.40
	120	32x7.40
	125	32x7.40

4535 bushings	Standard bore	Keyway (WxD)
4535	55	16x4.30
	60	18x4.40
	65	18x4.40
	70	20x4.90
	75	20x4.90
	80	22x5.40
	85	22x5.40
	90	25x5.40
	95	25x5.40
	100	28x6.40
	105	28x6.40
	110	28x6.40

5050 bushings	Standard bore	Keyway (WxD)
5050	70	20x4.90
	75	20x4.90
	80	22x5.40
	85	22x5.40
	90	25x5.40
	95	25x5.40
	100	28x6.40
	105	28x6.40
	110	28x6.40
	115	32x7.40
	120	32x7.40
	125	32x7.40

\* = Shallow key

**Taper bushings (Inch bore & keyway information)**

1008 bushings	Standard bore	Keyway (WxD)
1008	3/8	0.125x0.062
	1/2	0.125x0.062
	5/8	0.187x0.093
	3/4	0.187x0.093
	7/8	0.25x0.125
	1*	0.25x0.062

1108 bushings	Standard bore	Keyway (WxD)
1108	3/8	0.125x0.062
	1/2	0.125x0.062
	5/8	0.187x0.093
	3/4	0.187x0.093
	7/8	0.25x0.125
	1	0.25x0.125
	1-1/8*	0.312x0.078

1210 bushings	Standard bore	Keyway (WxD)
1210	3/8	0.125x0.062
	1/2	0.125x0.062
	5/8	0.187x0.093
	3/4	0.187x0.093
	7/8	0.25x0.125
	1	0.25x0.125
	1-1/8	0.312x0.125
	1-1/4	0.312x0.125

1215 bushings	Standard bore	Keyway (WxD)
1215	3/8	0.125x0.062
	1/2	0.125x0.062
	5/8	0.187x0.093
	3/4	0.187x0.093
	7/8	0.25x0.125
	1	0.25x0.125
	1-1/8	0.312x0.125
	1-1/4	0.312x0.125

1310 bushings	Standard bore	Keyway (WxD)
1310	1-1/16	0.312x0.125
	1-1/8	0.312x0.125
	1-3/16	0.312x0.125
	1-1/4	0.312x0.125
	1-5/16	0.375x0.125
	1-3/8	0.375x0.125

1610 bushings	Standard bore	Relevant keyway
1610	3/8	0.125x0.062
	1/2	0.125x0.062
	5/8	0.187x0.093
	3/4	0.187x0.093
	7/8	0.25x0.125
	1	0.25x0.125
	1-1/8	0.312x0.125
	1-1/4	0.312x0.125
	1-3/8	0.375x0.125
	1-1/2	0.375x0.125
	1-5/8*	0.437x0.125

1615 bushings	Standard bore	Keyway (WxD)
1615	3/8	0.125x0.062
	1/2	0.125x0.062
	5/8	0.187x0.093
	3/4	0.187x0.093
	7/8	0.25x0.125
	1	0.25x0.125
	1-1/8	0.312x0.125
	1-1/4	0.312x0.125
	1-3/8	0.375x0.125
	1-1/2	0.375x0.125
	1-5/8*	0.437x0.125

2012 bushings	Standard bore	Keyway (WxD)
2012	3/4	0.187x0.093
	7/8	0.25x0.125
	1	0.25x0.125
	1-1/8	0.312x0.125
	1-1/4	0.312x0.125
	1-3/8	0.375x0.125
	1-1/2	0.375x0.125
	1-5/8	0.437x0.156
	1-3/4	0.437x0.156
	1-7/8	0.50x0.156
	2	0.50x0.125

2517 bushings	Standard bore	Keyway
2517	3/4	0.187x0.093
	7/8	0.25x0.125
	1	0.25x0.125
	1-1/8	0.312x0.125
	1-1/4	0.312x0.125
	1-3/8	0.375x0.125
	1-1/2	0.375x0.125
	1-5/8	0.437x0.156
	1-3/4	0.437x0.156
	1-7/8	0.50x0.156
	2	0.50x0.125
	2-1/8	0.625x0.218
	2-1/4	0.625x0.218
	2-3/8	0.625x0.218
	2-1/2	0.625x0.218

2525 bushings	Standard bore	Keyway (WxD)
2525	3/4	0.187x0.093
	7/8	0.25x0.125
	1	0.25x0.125
	1-1/8	0.312x0.125
	1-1/4	0.312x0.125
	1-3/8	0.375x0.125
	1-1/2	0.375x0.125
	1-5/8	0.437x0.156
	1-3/4	0.437x0.156
	1-7/8	0.50x0.156
	2	0.50x0.125
	2-1/8	0.625x0.218
	2-1/4	0.625x0.218
	2-3/8	0.625x0.218
	2-1/2	0.625x0.218

3020 bushings	Standard bore	Keyway (WxD)
3020	1-1/4	0.312x0.125
	1-3/8	0.375x0.125
	1-1/2	0.375x0.125
	1-5/8	0.437x0.156
	1-3/4	0.437x0.156
	1-7/8	0.50x0.156
	2	0.50x0.156
	2-1/8	0.625x0.218
	2-1/4	0.625x0.218
	2-3/8	0.625x0.218
	2-1/2	0.625x0.218
	2-5/8	0.75x0.25
	2-3/4	0.75x0.25
	2-7/8	0.75x0.25
	3	0.75x0.25

3030 bushings	Standard bore	Keyway
3030	1-1/4	0.312x0.125
	1-3/8	0.375x0.125
	1-1/2	0.375x0.125
	1-5/8	0.437x0.156
	1-3/4	0.437x0.156
	1-7/8	0.50x0.156
	2	0.50x0.156
	2-1/8	0.625x0.218
	2-1/4	0.625x0.218
	2-3/8	0.625x0.218
	2-1/2	0.625x0.218
	2-5/8	0.75x0.25
	2-3/4	0.75x0.25
	2-7/8	0.75x0.25
	3	0.75x0.25

\* = SHALLOW KEY

**Taper bushings (Inch bore & keyway information)**

3525 bushings	Standard bore	Keyway (WxD)
3525	1-1/2	0.375x0.125
	1-5/8	0.437x0.156
	1-3/4	0.437x0.156
	1-7/8	0.50x0.156
	2	0.50x0.156
	2-1/8	0.625x0.218
	2-1/4	0.625x0.218
	2-3/8	0.625x0.218
	2-1/2	0.625x0.218
	2-5/8	0.75x0.25
	2-3/4	0.75x0.25
	2-7/8	0.75x0.25
	3	0.75x0.25
	3-1/8	0.875x0.312
	3-1/4	0.875x0.312
	3-3/8*	0.875x0.312
	3-1/2*	0.875x0.312

4040 bushings	Standard bore	Keyway (WxD)
4040	1-3/4	0.437x0.156
	1-7/8	0.50x0.156
	2	0.50x0.125
	2-1/8	0.625x0.218
	2-1/4	0.625x0.218
	2-3/8	0.625x0.218
	2-1/2	0.625x0.218
	2-5/8	0.75x0.25
	2-3/4	0.75x0.25
	2-7/8	0.75x0.25
	3	0.75x0.25
	3-1/8	0.875x0.312
	3-1/4	0.875x0.312
	3-3/8	0.875x0.312
	3-1/2	0.875x0.312
	3-3/4*	1.0x0.25
	4*	1.0x0.25

5040 bushings	Standard bore	Keyway (WxD)
5040	2-3/4	0.75x0.25
	2-7/8	0.75x0.25
	3	0.75x0.25
	3-1/8	0.875x0.312
	3-1/4	0.875x0.312
	3-3/8	0.875x0.312
	3-1/2	0.875x0.312
	3-3/4	1.0x0.375
	4	1.0x0.375
	4-1/4	1.25x0.437
	4-1/2	1.25x0.437
	4-3/4	1.25x0.437
5*	1.25x0.312	

3535 bushings	Standard bore	Keyway (WxD)
3535	1-1/2	0.375x0.125
	1-5/8	0.437x0.156
	1-3/4	0.437x0.156
	1-7/8	0.50x0.156
	2	0.50x0.156
	2-1/8	0.625x0.218
	2-1/4	0.625x0.218
	2-3/8	0.625x0.218
	2-1/2	0.625x0.218
	2-5/8	0.75x0.25
	2-3/4	0.75x0.25
	2-7/8	0.75x0.25
	3	0.75x0.25
	3-1/8	0.875x0.312
	3-1/4	0.875x0.312
	3-3/8*	0.875x0.25
	3-1/2*	0.875x0.25

4535 bushings	Standard bore	Keyway (WxD)
4535	2-1/4	0.625x0.218
	2-3/8	0.625x0.218
	2-1/2	0.625x0.218
	2-5/8	0.75x0.25
	2-3/4	0.75x0.25
	2-7/8	0.75x0.25
	3	0.75x0.25
	3-1/8	0.875x0.312
	3-1/4	0.875x0.312
	3-3/8	0.875x0.312
	3-1/2	0.875x0.312
	3-3/4	1.0x0.375
	4	1.0x0.375
	4-1/4*	1.25x0.25
	4-1/2*	1.25x0.25

5050 bushings	Standard bore	Keyway (WxD)
5050	2-3/4	0.75x0.25
	2-7/8	0.75x0.25
	3	0.75x0.25
	3-1/8	0.875x0.312
	3-1/4	0.875x0.312
	3-3/8	0.875x0.312
	3-1/2	0.875x0.312
	3-3/4	1.0x0.375
	4	1.0x0.375
	4-1/4	1.25x0.437
	4-1/2	1.25x0.437
	4-3/4	1.25x0.437
5*	1.25x0.312	

\* = SHALLOW KEY

4030 bushings	Standard bore	Keyway (WxD)
4030	1-3/4	0.437x0.156
	1-7/8	0.50x0.156
	2	0.50x0.156
	2-1/8	0.625x0.218
	2-1/4	0.625x0.218
	2-3/8	0.625x0.218
	2-1/2	0.625x0.218
	2-5/8	0.75x0.25
	2-3/4	0.75x0.25
	2-7/8	0.75x0.25
	3	0.75x0.25
	3-1/8	0.875x0.312
	3-1/4	0.875x0.312
	3-3/8	0.875x0.312
	3-1/2	0.875x0.312
	3-3/4*	1.0x0.375
	4*	1.0x0.375

4545 bushings	Standard bore	Keyway (WxD)
4545	2-1/4	0.625x0.218
	2-3/8	0.625x0.218
	2-1/2	0.625x0.218
	2-5/8	0.75x0.25
	2-3/4	0.75x0.25
	2-7/8	0.75x0.25
	3	0.75x0.25
	3-1/8	0.875x0.312
	3-1/4	0.875x0.312
	3-3/8	0.875x0.312
	3-1/2	0.875x0.312
	3-3/4	1.0x0.375
	4	1.0x0.375
	4-1/4*	1.25x0.25
	4-1/2*	1.25x0.25